

ELECTRONIC SHAFT-EXTRACTING LIFTING TROLLEY

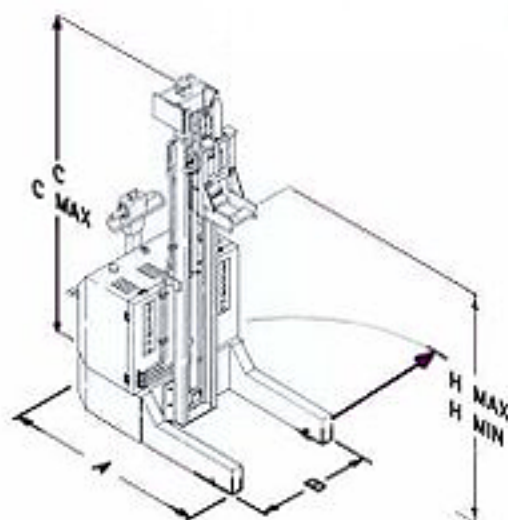

A	mm	:	1280
B	mm	:	890
C	mm	:	1750
H max	mm	:	2000
H min	mm	:	170
R	mm	:	1060

Model	COYOTE1		
Capacity	Kg.	:	800
Carriage weight	Kg.	:	± 450
Traction battery	Aph	:	195
Autonomy hours	h.	:	8/9
Battery charger	supplied on request		
Acoustic emission	dB	:	less than 67

FUNCTIONING

All lifting and clamping is achieved electro-hydraulically. Driving motion is through electric motor.

WORK POSITION

The operator's work position is behind the machine in the direction of movement.

LIGHTING AND HEALTH CONDITIONS AT THE WORK POSITION

In line with the provisions for light in the work environment, the place where the machine is installed must not have shadowed areas, bright lights or dangerous stroboscopic effects due to the surrounding machines.

The SELF-PROPELLED TROLLEY has been designed for the extraction and handling of expanding shafts and chucks from a reel of wound material, such as paper of various basis weights, and for the re-insertion of the same in paper core or cores which have been suitably prepared by the operator. The unit has been manufactured according to the strictest accident-prevention standards and maintains optimum efficiency even in extended use. It is composed of a base frame mounted on wheels, an electro-hydraulic pump, and a piston which drives a vertical carriage, which in turn supports a hydraulically-powered vice, in which the shaft is clamped. The vehicle is electrically powered, via a high-capacity battery.



APRIL 2000

Goldenrod Corporation 100 Union City Road
Prospect, CT 06712 203-758-0100 800-465-3763

Svecom, P.E.