



JARSHIRE
WASTE & RECYCLING

LEVELS HOUSE, BRISTOL WAY, STOKE
GARDENS, SLOUGH, BERKSHIRE SL1 3QE
Tel: 01753 825 122
E-mail: njobson@jarshire.co.uk



Vertical Baler: V32

Our standard high density baler has an economical yet dependable design.

This model is ideal for Retailers, Grocery Stores, Drug Stores, and other organizations that recycle OCC or Plastic Film.

Ideal For:

- Grocery Stores
- Home Retailers
- Pharmacies
- Big Box Retailers
- National Accounts
- Commissaries
- Warehouses
- Distribution Centres
- Hospitals, Schools & Universities
- Recyclers



BACE Vertical Balers meet or exceed all existing ANSI & OSHA Safety Standards and are totally 100% ETL & CETL Approved.



JARSHIRE
WASTE & RECYCLING

156.50"
3975mm

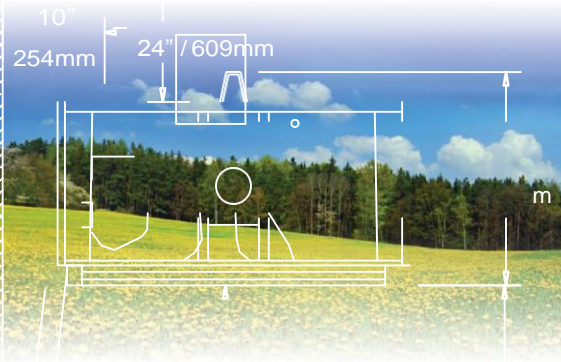

Vertical Baler: V32

The V32 baler is compact and space saving without sacrificing quality and durability. It is ideal for customers with space constraints.

Specifications

Performance

Nominal Bale Size	
Bale Weight	Up to
Bale Volume	0.42
No. of Bale Tie Slots	4
Compact Force cubic metre - Based on Factory Set (psi)	340
Average Cycle Time	40 Seconds
Loading Height	
Ejector System	Semi-Automatic
Full Bale Light	Optional
Hydraulic / Electrical	
Motor KW	1.5KW
Voltage 3 Phase Full Load Amps (A = Amps)	400Volt 32 amp
Pump LPM	11 LPM
Factory Set System Pressure PSI	1700
Cylinder Bore x Stroke	76.2mm x 762mm
Hydraulic Reservoir Capacity	34 litres
ADDITIONAL HYDRAULIC/ELECTRICAL CONFIGURATIONS ARE AVAILABLE. PLEASE CALL BACE FOR MORE INFORMATION.	

Available Options:

- Oil Heater
- Weather Proof Package
- Full Bale Light

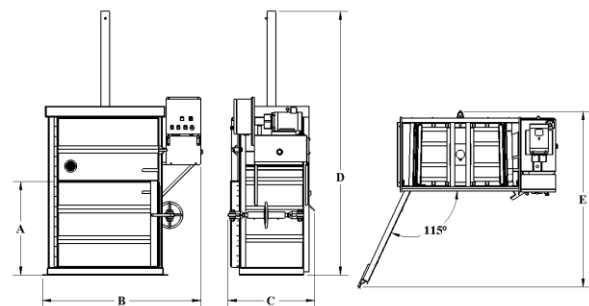

DIM. (in./mm)	A	B	C	D	E
V32	889	1499	813	2515	1676

Due to continual product improvement JARSHIRE reserves the right to change specifications without notice.
The information and pictures used in the document are for illustrative purposes only. Printed on recycled paper. January 2017



JARSHIRE
WASTE & RECYCLING

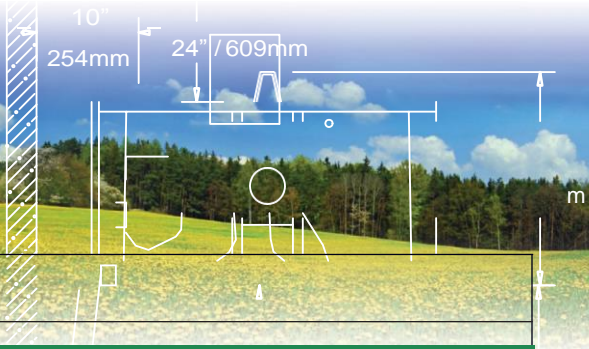

Customer Order Form: V32

Bill To	Ship To
Company: (Legal Name)	Company: (Legal Name)
Address:	Address:
Post Code:	Pose Code:
Attention:	Attention:
Phone:	Phone:
Fax:	Fax:

Order Details

Select HP / Voltage and Electrical Requirements - Standard Power Unit(s)

	Motor Kw	Voltage	Full Load Amps	Power Supply Required
<input type="radio"/>	1.5	208V	13	30
<input type="radio"/>	1.5	230V	12	30
<input type="radio"/>	1.5	440/480V	8	20

Customer is required to supply a fused disconnect and 12' pigtail

<input type="checkbox"/>	Paid Options - Call for Pricing	Choose Door Swing - Drawing shows LEFT HAND
<input type="checkbox"/>	Optional Power _____ V _____ HZ _____ PHASE	Lay-out based on side of hinge when facing the baler.
<input type="checkbox"/>	Single Phase Power Unit	
<input type="checkbox"/>	Rear Wire Guides	<input type="radio"/> LEFT HAND HINGE ONLY
<input type="checkbox"/>	Full Bale Light	
<input type="checkbox"/>	Oil Heater	
<input type="checkbox"/>	Weather Proof (outdoor use)	
<input type="checkbox"/>	Wire (\$90 per bundle) #	
<input type="checkbox"/>	Custom Colour / Colour Code:	
<input type="checkbox"/>	Custom Logo / No charge	
<input type="checkbox"/>	Standard Colours / No Charge <input type="checkbox"/> Grey <input type="checkbox"/> Green <input type="checkbox"/> Blue	

DIM. (in./mm)	A	B	C	D	E
V32	889	1499	813	2515	1676



JARSHIRE
WASTE & RECYCLING

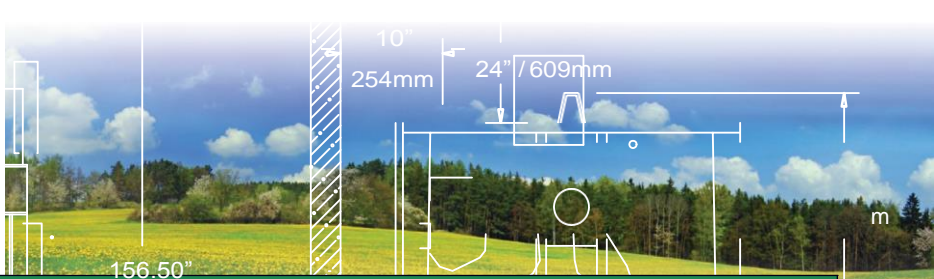

Customer Installation Details

Contact Information	Installation Questions	
Company:	Do you have a loading dock with an 8' wide door?	<input type="radio"/> YES <input type="radio"/> NO
Address:	What is your ceiling height?	
	Any obstacles (steps, grade change, overhead pipes, etc.)	<input type="radio"/> YES <input type="radio"/> NO
Post Code:	Do we need to remove an existing baler?	<input type="radio"/> YES <input type="radio"/> NO
Attention:	Do you have a forklift on site? (If no, a \$350 forklift fee will apply)	<input type="radio"/> YES <input type="radio"/> NO
Phone:	What is the capacity of your forklift?	<input type="radio"/> YES <input type="radio"/> NO
Fax:		

Provide a diagram for the proposed location of the baler similar to the drawing below.

